

1. PRODUCT NAME

Handrailing system bearing the name AZTEC

2. MANUFACTURER

Livers Bronze Co. exclusively manufactures the handrail system as described on this sheet.

Livers Bronze Co.
4621 East 75th Terrace
Kansas City, MO 64132

Phone: (816) 300 2828
Fax: (816) 300 0864
e-mail: livers@liversbronze.com

3. BASIC USE

Livers Bronze Co. AZTEC system is a pre-engineered component based railing system, shipped to the jobsite ready to install.

LIMITATIONS: AZTEC railing system is only limited by the materials from which it is fabricated.

Pre-engineered railing should be assembled using the components listed:

42" high guardrail post of extruded aluminum. Spaced @ 5'-0" O.C. maximum.

42" high guardrail post of extruded aluminum with a 34" high side mounted handrail. Spaced @ 5'-0" O.C. maximum.

1 1/2" Diameter metal handrail in 304 stainless steel, Alloy #230 red brass, painted metal.

1/2" tempered glass infill furnished by Livers Bronze Co. for field attaching to post.

FINISHES: A wide selection of colors and textures in powder coat is available for post finishes. Colors are selected from manufacturers standard color charts. Standard circular satin and polished finishes are available for stainless steel and bronze railings. Anodized finishes are not available.

continued on other side...

AZTEC

Railing System

Product Data Sheet

Visit our website for:

- AutoCAD Details
- CSI format guide specifications
- Photos

www.liversbronze.com

Livers

Bronze Co.

4621 East 75th Terrace
Kansas City, MO 64132

Phone: (816) 300 2828
Fax: (816) 300 0864
e-mail: livers@liversbronze.com

Railing Systems from the Industry Leader

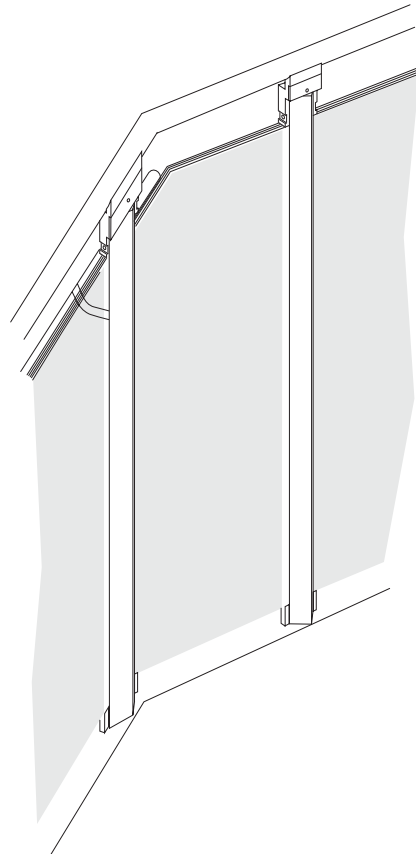

AZTEC
Product Data Sheet

Livers

4. TECHNICAL DATA

The AZTEC railing system conforms to IBC and ADA regulations for openings and stress.

5. INSTALLATION

Livers Bronze AZTEC railing system must be attached with fasteners and to surfaces that are approved or selected by the manufacturer and shall be detailed on all shop drawings.

6. AVAILABILITY AND COST

Cost: Varies according to quantity and materials. Further information may be obtained from Livers Bronze Co. or one of their authorized representatives.

Availability: AZTEC railing system is subject to current delivery schedules. Each project must be reviewed before scheduling is available.

7. GUARANTEE

Livers Bronze warrants that its AZTEC railing system is of sound quality, conforming to standards as stated in part 4

hereof and is reasonably free of defects in material and workmanship. Inasmuch as Livers Bronze has no control over the installation of its products, no other warranty is expressed or implied. Livers Bronze Co. does not warranty against glass breakage.

8. MAINTENANCE

The surface of Livers Bronze Co. material can be kept clean by the use of ordinary soaps and mild cleansers. Abrasive cleaners should not be used.

9. TECHNICAL SERVICES

Technical services are rendered direct from the Livers Bronze Company in Kansas City, Missouri.

10. FILING SYSTEM

Sweet's Architectural file.

Sweets.com

Literature available on request.

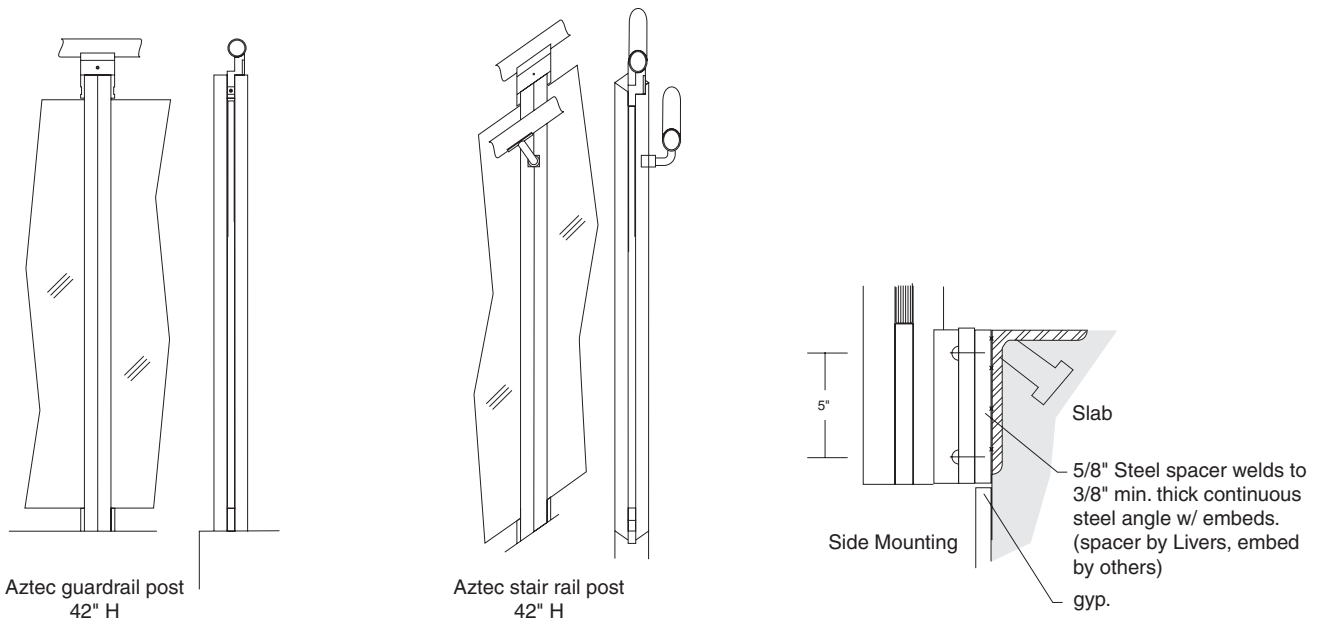

AutoCAD details & specifications are available at:

www.liversbronze.com

Livers

4621 East 75th Terrace
Kansas City, MO 64132

Bronze Co.

Phone: (816) 300 2828
Fax: (816) 300 0864
e-mail: livers@liversbronze.com