

1. PRODUCT NAME

Handrailing system bearing the name FONTANA

2. MANUFACTURER

Livers Bronze Co. exclusively manufactures the handrail system as described on this sheet.

Livers Bronze Co.
4621 East 75th Terrace
Kansas City, MO 64132

Phone: (816) 300 2828
Fax: (816) 300 0864
e-mail: livers@liversbronze.com

3. BASIC USE: Livers Bronze Co. FONTANA system is a pre-engineered component based railing system, shipped to the jobsite ready to install.

LIMITATIONS: FONTANA railing system is only limited by the materials from which it is fabricated. For radius stair applications please consult Livers Bronze Co.

Pre-engineered railing should be assembled using the components listed:

FON8000 34" high 2" O.D. post for 42" high glass infill applications. Shall be painted cold rolled steel spaced at 4' - 0" O.C. maximum.

Assist rail: 1.5" round steel, stainless steel, aluminum or bronze.

3/8" clear tempered glass furnished by Livers Bronze Co. for attaching to FONTANA post.

Finishes: A wide selection of colors and textures in powder coat is available for posts. Colors are selected from manufacturers standard color charts. Standard circular grain satin and polished finishes are available for stainless steel and bronze railing. Anodized finishes are not available.

4. TECHNICAL DATA

The FONTANA railing system conforms to ADA and IBC regulations for openings and stress.

5. INSTALLATION

Livers Bronze Co. FONTANA railing system must be attached with fasteners and to surfaces that are approved or selected by the manufacturer and shall be detailed on all shop drawings.

continued on other side...

FONTANA

Railing System

Product Data Sheet

Visit our website for:

- AutoCAD Details
- CSI format guide specifications
- Photos

www.liversbronze.com

Livers

Bronze Co.

4621 East 75th Terrace
Kansas City, MO 64132

Phone: (816) 300 2828
Fax: (816) 300 0864
e-mail: livers@liversbronze.com

Railing Systems from the Industry Leader

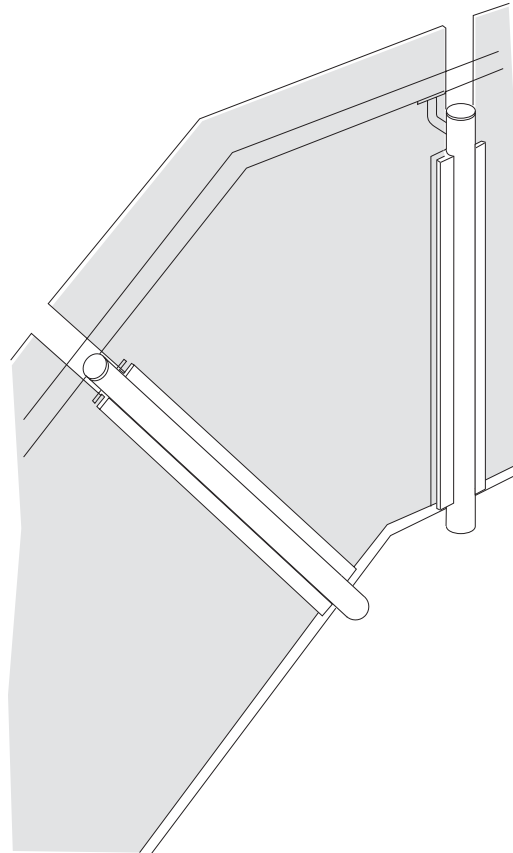

FONTANA
Product Data Sheet

Livers

6. AVAILABILITY AND COST

Cost: Varies according to quantity and material. Further information may be obtained from Livers Bronze Co. or one of their authorized representatives.

Availability: FONTANA railing system is subject to current delivery schedules. Each project must be reviewed before scheduling is available.

7. GUARANTEE

Livers Bronze Co. warrants that its FONTANA railing system is of sound quality, conforming to standards as stated in part 4 hereof and is reasonably free of defects in material and workmanship. Inasmuch as Livers Bronze has no control over the installation of its products, no other warranty is expressed or implied. Livers Bronze Co. does not warranty against glass breakage.

8. MAINTENANCE

The surface of Livers Bronze Co. material can be kept clean by the use of ordinary soaps and mild cleansers. Abrasive cleaners should not be used.

9. TECHNICAL SERVICES

Technical services are rendered direct from the Livers Bronze Company in Kansas City, Missouri.

10. FILING SYSTEM

Sweet's Architectural file.

Sweets.com

Literature available on request.

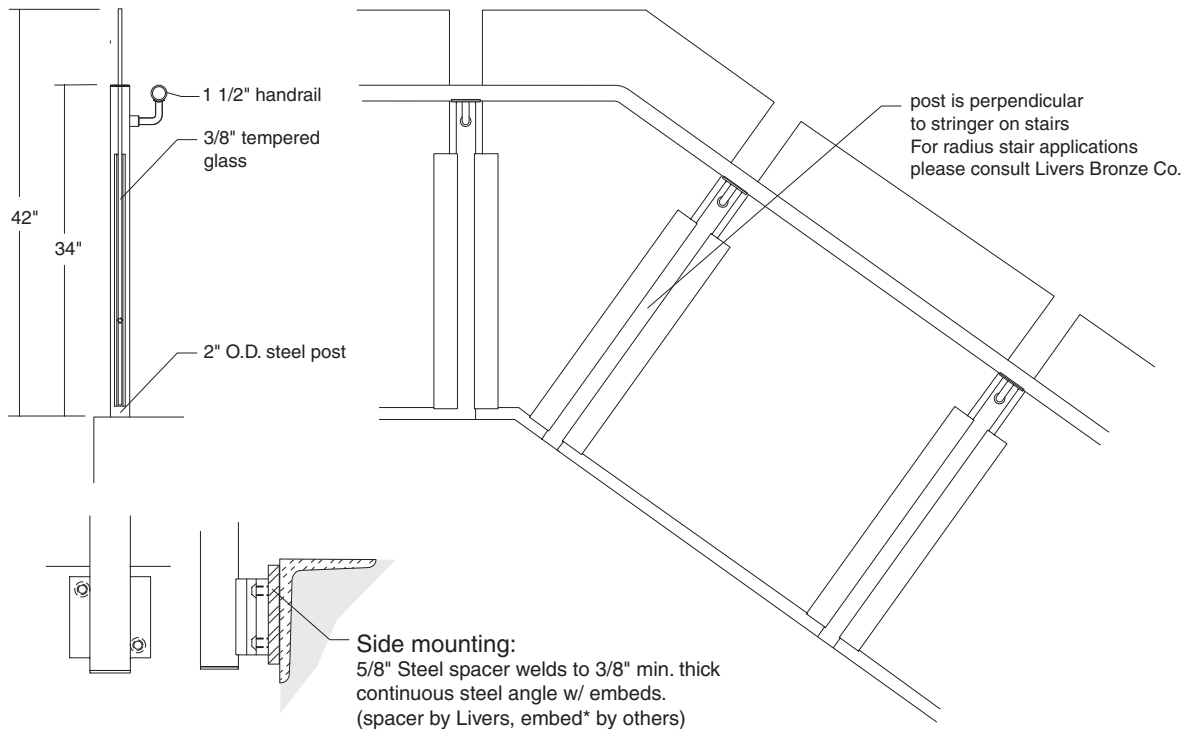
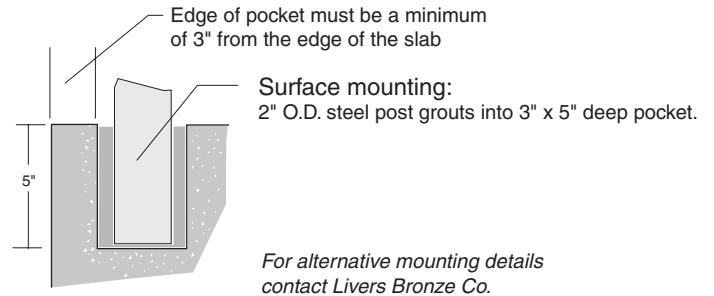

AutoCAD details & specifications are available at:
www.liversbronze.com

Livers

Bronze Co.

4621 East 75th Terrace
Kansas City, MO 64132

Phone: (816) 300 2828
Fax: (816) 300 0864
e-mail: livers@liversbronze.com

