

BELMONT

Product Data Sheet

1. PRODUCT NAME

Handrailing system bearing the name BELMONT

2. MANUFACTURER

Livers Bronze Co. exclusively manufactures the handrail system as described on this sheet.

Livers Bronze Co.
4621 East 75th Terrace
Kansas City, MO 64132

Phone: (816) 300 2828
Fax: (816) 300 0864
e-mail: livers@liversbronze.com

3. BASIC USE

Livers Bronze Co. BELMONT system is a pre-engineered component based railing system, shipped to the jobsite ready to install.

LIMITATIONS: BELMONT railing system is only limited by the materials from which it is fabricated.

Pre-engineered railing should be assembled using the components listed:

42" high guardrail post of extruded aluminum. Spaced @ 5'-0" O.C. maximum.

42" high guardrail post for glass infill applications. Shall be powder coated cold rolled steel or type 304 #4 stainless steel (Belmont-SS) spaced at 4' - 0" O.C. maximum.

42" high guardrail post for tempered glass infill applications w/side bounted handrail at 34" above stair nosing. Post spaced at 4'-0" OC maximum.

Top rail: 1.5' round steel, stainless steel, aluminum or bronze. (2" round minimum for wood top rail.) Assist rail: 1.5" round stainless steel, aluminum or bronze.

3/8" tempered glass infill furnished by Livers Bronze Co. for field attaching to BELMONT post.

FINISHES: A wide selection of colors and textures in powder coat is available for post finishes. Colors are selected from manufacturers standard color charts. Standard circular satin and polished finishes are available for stainless steel and bronze railings. Anodized finished are not available.

4. TECHNICAL DATA

The BELMONT railing system conforms to IBC and ADA regulations for openings and stress.

5. INSTALLATION

Livers Bronze BELMONT railing system must be attached with fasteners and to surfaces that are approved or selected by the manufacturer and shall be detailed on all shop drawings.

6. AVAILABILITY AND COST

Cost: Varies according to quantity and materials. Further information may be obtained from Livers Bronze Co. or one of their authorized representatives.

Availability: BELMONT railing system is subject to current delivery schedules. Each project must be reviewed before scheduling is available.

7. GUARANTEE

Livers Bronze warrants that its BELMONT railing system is of sound quality, conforming to standards as stated in part 4 hereof and is reasonably free of defects in material and workmanship. Inasmuch as Livers Bronze has no control over the installation of its products, no other warranty is expressed or implied. Livers Bronze Co. does not warranty against glass breakage.

8. MAINTENANCE

The surface of Livers Bronze Co. material can be kept clean by the use of ordinary soaps and mild cleansers. Abrasive cleaners should not be used.

9. TECHNICAL SERVICES

Technical services are rendered direct from the Livers Bronze Company in Kansas City, Missouri.

10. FILING SYSTEM

Sweet's Architectural file.
Sweets.com
Literature available on request.

Innovative by Design

AutoCAD details & specifications are available at: www.liversbronze.com

4621 East 75th Terrace
Kansas City, MO 64132

© 2008 Livers Bronze Co.

Phone: (816) 300 2828
Fax: (816) 300 0864
e-mail: livers@liversbronze.com



RAILING SYSTEMS

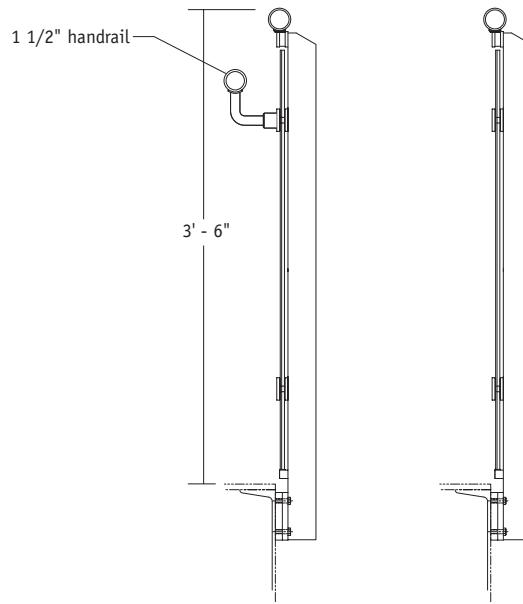
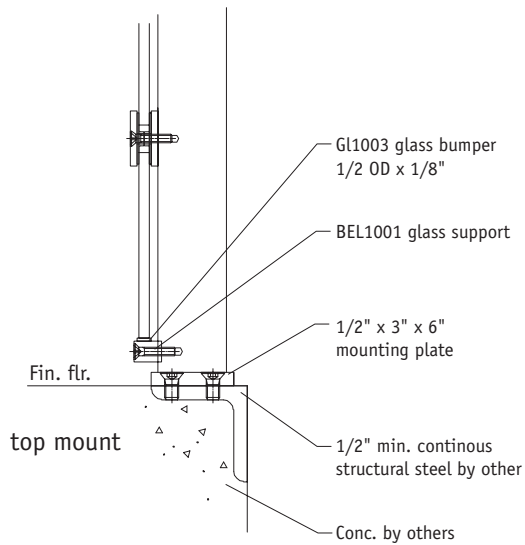

Belmont guardrail post
42" H

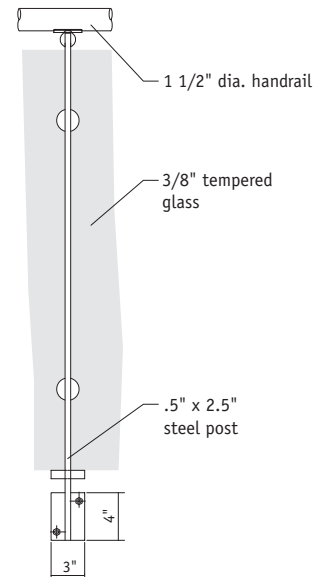
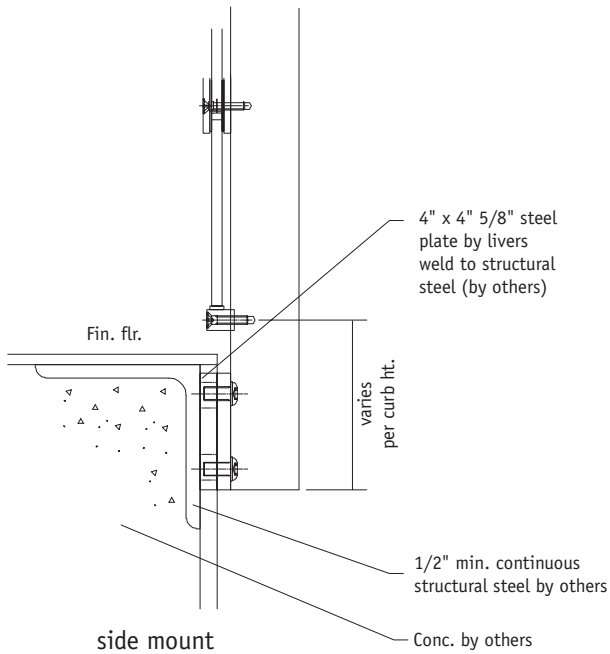

Innovative by Design

AutoCAD details & specifications are available at: www.liversbronze.com

4621 East 75th Terrace
Kansas City, MO 64132

Phone: (816) 300 2828
Fax: (816) 300 0864
e-mail: livers@liversbronze.com



RAILING SYSTEMS