

Disc

Product Data Sheet

1. PRODUCT NAME

Handrailing system bearing the name DISC

2. MANUFACTURER

Livers Bronze Co. exclusively manufactures the handrail system as described on this sheet.

Livers Bronze Co.
4621 East 75th Terrace
Kansas City, MO 64132

Phone: (816) 300 2828
Fax: (816) 300 0864
e-mail: livers@liversbronze.com

3. BASIC USE

Livers Bronze Co. DISC system is a pre-engineered component based railing system, shipped to the jobsite ready to install.

Limitations: DISC railings system is only limited by the materials from which it is fabricated.

Pre-engineered railing should be assembled using the components listed:

42" high guardrail post shall be of powder coated steel and machined aluminum, spaced at 5'-0" O.C. maximum.

42" high with a 34" high side mounted handrail

Handrail may be 1 1/2" or 2" diameter metal, extruded aluminum, 304 stainless steel, alloy #230 red brass or hardwood (Sanded, specify species). Note: wood rail only available in 2" Dia.

1/2" tempered glass furnished by Livers Bronze Co. for attaching in the field to the post assembly.

Finishes: A wide selection of colors and textures in powder coat are available. Colors are selected from manufacturers standard color charts.

4. TECHNICAL DATA

The DISC railing system conforms to IBC and ADA regulations for openings and stress.

5. INSTALLATION

Livers Bronze Co. DISC railing system must be attached with fasteners and to surfaces that are approved or selected by the manufacturer and shall be detailed on all shop drawings.

6. AVAILABILITY AND COST

Cost: Varies according to quantity and materials. Further information may be obtained from Livers Bronze Co. or one of their authorized representatives.

Availability: DISC railing system is subject to current delivery schedules. Each project must be reviewed before scheduling is available.

7. GUARANTEE

Livers Bronze Co. warrants that its DISC railing system is of sound quality. Conforming to standards as stated in part 4 hereof and are reasonably free of defects in material and workmanship. Inasmuch as Livers Bronze Co. has no control over the installation of its products, no other warranty is expressed or implied. Livers Bronze Co. does not warranty against glass breakage.

8. MAINTENANCE

The surface of Livers Bronze material can be kept clean by the use of ordinary soaps and mild cleansers. Abrasive cleaners should not be used.

9. TECHNICAL SERVICES

Technical services are rendered direct from the Livers Bronze Company in Kansas City, Missouri.

10. FILING SYSTEM

Sweet's Architectural file.
Sweets.com
Literature available on request.

Innovative by Design

AutoCAD details & specifications are available at: www.liversbronze.com

4621 East 75th Terrace
Kansas City, MO 64132

© 2008 Livers Bronze Co.

Phone: (816) 300 2828
Fax: (816) 300 0864
e-mail: livers@liversbronze.com



RAILING SYSTEMS

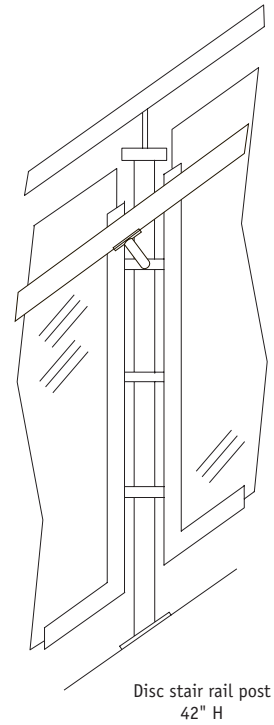
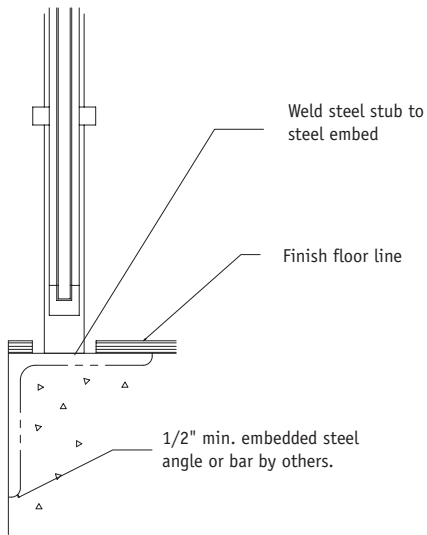
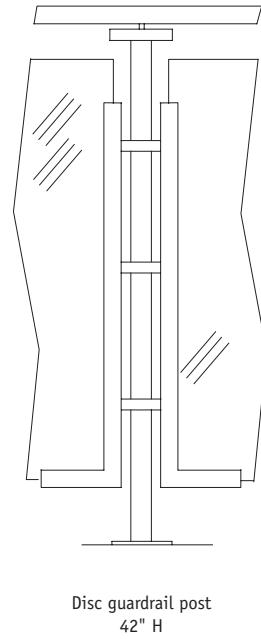
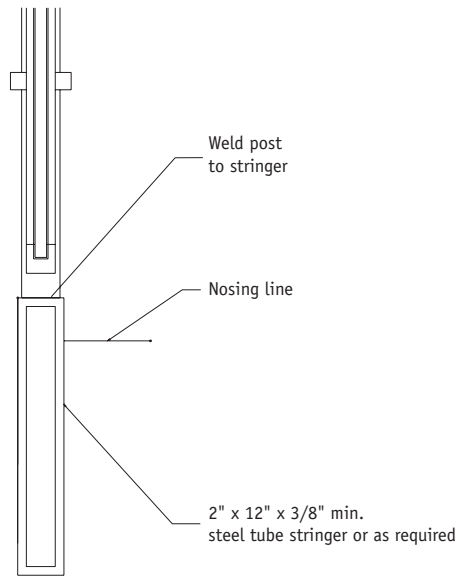

Innovative by Design

AutoCAD details & specifications are available at: www.liversbronze.com

4621 East 75th Terrace
Kansas City, MO 64132

Phone: (816) 300 2828
Fax: (816) 300 0864
e-mail: livers@liversbronze.com

© 2008 Livers Bronze Co.



RAILING SYSTEMS