

STRATA

Product Data Sheet

1. PRODUCT NAME

Handrailing system bearing the name STRATA

2. MANUFACTURER

Livers Bronze Co. exclusively manufactures the handrail system as described on this sheet.

Livers Bronze Co.
4621 East 75th Terrace
Kansas City, MO 64132

Phone: (816) 300 2828
Fax: (816) 300 0864
e-mail: livers@liversbronze.com

3. BASIC USE

Livers Bronze Co. STRATA system is a pre-engineered component based railing system, shipped to the jobsite ready to install.

Pre-engineered railing should be assembled using the components listed:

42" high guardrail post for tempered glass infill applications. Shall be stainless steel spaced at 4'-0" O.C. maximum.

42" high guardrail post for tempered plate glass infill applications w/ 34" high side mounted handrail. Shall be stainless steel spaced at 4'-0" O.C. maximum.

42" high alternate guardrail post for tempered glass infill applications. Shall be stainless steel spaced at 4'-0" O.C. maximum.

Top railing is 2" dia. stainless steel or 2" dia. hardwood(specify species)

Handrail is 1 1/2" diameter stainless steel.

3/8" tempered glass furnished by Livers Bronze Co. for attaching to posts.

Finishes: Standard directional #4 satin, standard circular grain and polished #7 finishes are available for stainless steel railing components. Wood rails to be sanded, final field finishing by others.

4. TECHNICAL DATA

The STRATA railing system conforms to IBC and ADA regulations for openings and stress.

5. INSTALLATION

Livers Bronze Co. STRATA railing system must be attached with fasteners and to surfaces that are approved or selected by the manufacturer and shall be detailed on all shop drawings.

6. AVAILABILITY AND COST

Cost: Varies according to quantity and material. Further information may be obtained from Livers Bronze Co. or one of their authorized representatives.

Availability: STRATA railing system is subject to current delivery schedules. Each project must be reviewed before scheduling is available.

7. GUARANTEE

Livers Bronze Co. warrants that its STRATA railing system is of sound quality, conforming to standards as stated in part 4 hereof and are reasonably free of defects in material and workmanship. Inasmuch as Livers Bronze has no control over the installation of its products, no other warranty is expressed or implied. Livers Bronze does not warranty against glass breakage.

8. MAINTENANCE

The surface of Livers Bronze material can be kept clean by the use of ordinary soaps and mild cleansers. Abrasive cleaners should not be used.

9. TECHNICAL SERVICES

Technical services are rendered direct from the Livers Bronze Co. in Kansas City, Missouri.

10. FILING SYSTEM

Sweet's Architectural file.
Sweets.com
Literature available on request.

Innovative by Design

AutoCAD details & specifications are available at: www.liversbronze.com

4621 East 75th Terrace
Kansas City, MO 64132

© 2008 Livers Bronze Co.

Phone: (816) 300 2828
Fax: (816) 300 0864
e-mail: livers@liversbronze.com



RAILING SYSTEMS

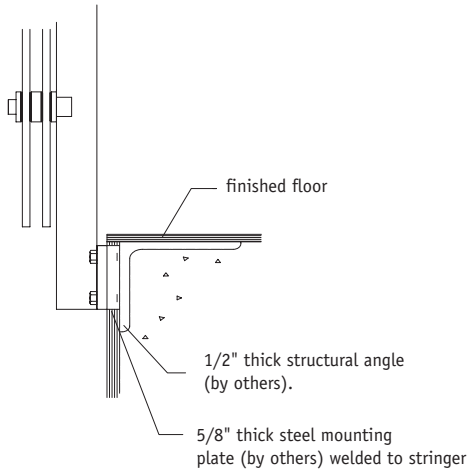

Side mounting detail

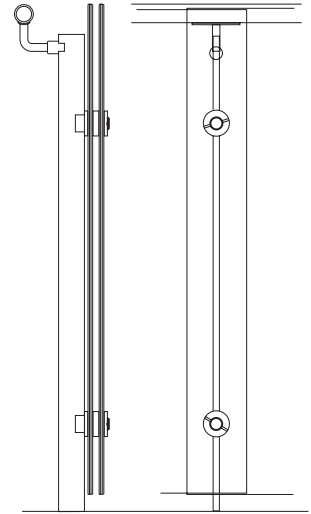

Optional Strata guardrail post
42" H

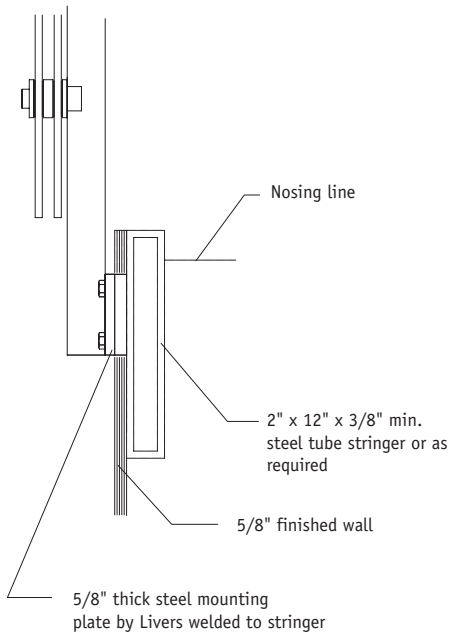

Stringer mounting detail

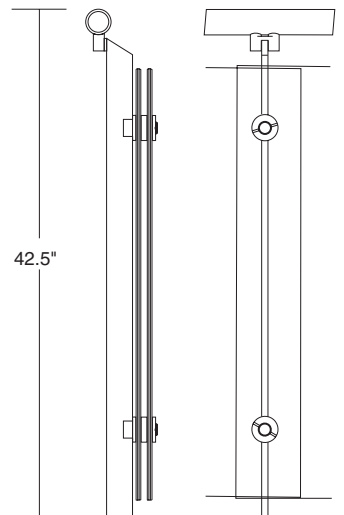

Strata guardrail post
42" H

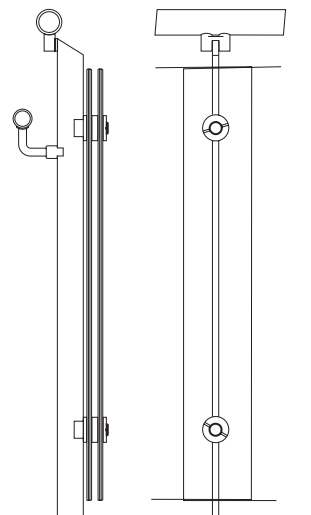

Strata stair rail post
42" H

Innovative by Design

AutoCAD details & specifications are available at: www.liversbronze.com

4621 East 75th Terrace
Kansas City, MO 64132

Phone: (816) 300 2828
Fax: (816) 300 0864
e-mail: livers@liversbronze.com

© 2008 Livers Bronze Co.



RAILING SYSTEMS